

# 10% SAVINGS

## On All Kaiser Series EWN 2-50XL Integral Boring Heads With Radial Adjustment Tool & Insert Holders

**Kaiser Integral Boring Heads – One Piece Construction and Shorter Projection Provides Higher Rigidity & Less Components for an Overall Lower Cost!**



- Dial adjustment of .0002"/div. with Vernier markings of .00005"/div. and large face dial means easy and precise adjustments at the machine.
- Boring range of  $\varnothing$ .078" - 2.125" and  $\varnothing$ 3.15" - 6.00" with standard components.
- Additional accessories allow for counter-boring, back-boring, chamfering and even O.D. turning.
- Available in CV40, BT40, HSK-A63 and Capto® C6 integral shanks.

**Radial Adjustment Tool & Insert Holders – Keeps the Tool Holder Mass at the Center of Rotation for Optimal Tool Balance!**

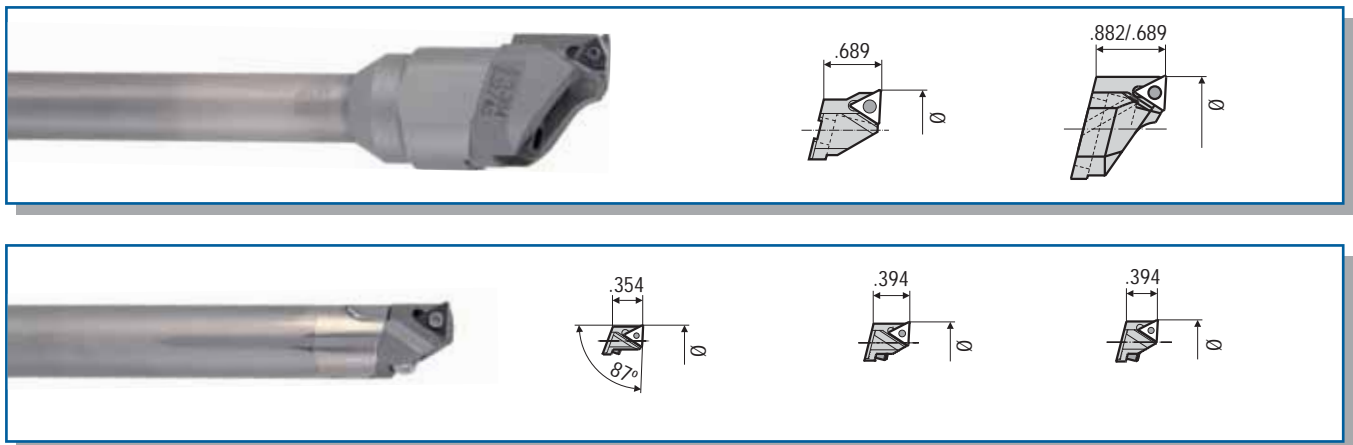

- For exclusive use with TP07 & TC11 inserts only – diameter range of .386" - 2.125".
- Reduces tool imbalance for higher cutting speeds and feeds.

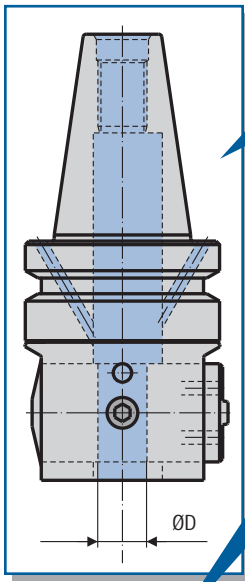

### INTEGRAL BORING HEAD \*

GRADUATIONS	CATALOG NUMBER	DESCRIPTION	ØD	Ø RANGE
Inch	10.112.132	Finish Head EWN 2-50XL x BT40	.625"	.078" - 2.125" & 3.15" - 6.00"
	10.112.133	Finish Head EWN 2-50XL x HSK-A63		
	10.112.134	Finish Head EWN 2-50XL x CV40		
	10.470.118	Finish Head EWN 2-50XL x C6		
Metric	10.112.122	Finish Head EWN 2-50XL x BT40	16mm	2 - 54mm & 80 - 152mm
	10.112.123	Finish Head EWN 2-50XL x HSK-A63		
	10.470.108	Finish Head EWN 2-50XL x C6		

### REDUCTION BUSHING

CATALOG NUMBER	DESCRIPTION	ØD	Ød
10.613.529	Reduction Bushing 5/8 RB 9 x C3.9	.625"	9mm
10.613.511	Reduction Bushing 5/8 RB 11	.625"	11mm
10.613.513	Reduction Bushing 5/8 RB 13	.625"	13mm
10.613.409	Reduction Bushing 16 RB 9	16mm	9mm
10.613.411	Reduction Bushing 16 RB 11	16mm	11mm
10.613.413	Reduction Bushing 16 RB 13	16mm	13mm

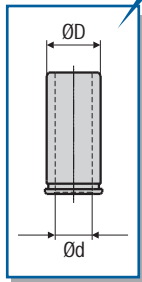

### RADIAL ADJUSTMENT TOOL HOLDER \*

CATALOG NUMBER	DESCRIPTION	ØD	L
10.615.261	5/8" x 3.15 Steel Bar/RATH .7-1.3	.625"	3.858"(ST)
10.615.254	5/8" x 3.94 Carbide Bar/RATH .7-1.3	.625"	4.645"
10.615.255	5/8" x 6.3 Carbide Bar/RATH .7-1.3	.625"	7.008"
10.615.263	5/8" x 3.54 Steel Bar/RATH 1.26-2.12	.625"	4.005"(ST)
10.615.259	5/8" x 4.33 Carbide Bar/RATH 1.26-2.12	.625"	5.197"
10.615.260	5/8" x 6.3 Carbide Bar/RATH 1.26-2.12	.625"	6.811"
10.615.369	9mm x 100 Carbide Bar/RATH 10-12	9mm	4.764"
10.615.371	11mm x 120 Carbide Bar/RATH 12-14	11mm	5.512"
10.615.373	13mm x 130 Carbide Bar/RATH 14-17	13mm	6.120"
10.615.262	16mm x 80 Steel Bar/RATH 18-33	16mm	3.858"
10.615.252	16mm x 100 Carbide Bar/RATH 18-33	16mm	4.646"
10.615.253	16mm x 160 Carbide Bar/RATH 18-33	16mm	7.008"
10.615.264	16mm x 90 Steel Bar/RATH 32-54	16mm	4.055"
10.615.257	16mm x 110 Carbide Bar/RATH 32-54	16mm	4.843"
10.615.258	16mm x 160 Carbide Bar/RATH 32-54	16mm	6.811"

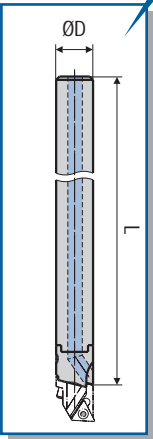

### RADIAL ADJUSTMENT INSERT HOLDER \*

CATALOG NUMBER	DESCRIPTION	Ø RANGE	L
10.615.365	Insert Holder E10-12 TP07	.386" - .472"	.354"
10.615.366	Insert Holder E12-14 TP07	.465" - .551"	.394"
10.615.367	Insert Holder E14-17 TP07	.543" - .669"	.394"
10.615.301	Insert Holder E18-22 TC11	.661" - .866"	.689"
10.615.302	Insert Holder E22-27 TC11	.858" - 1.063"	.689"
10.615.303	Insert Holder E27-33 TC11	1.055" - 1.299"	.689"
10.615.304	Insert Holder E32-40 TC11	1.252" - 1.575"	.882"
10.615.305	Insert Holder E40-54 TC11	1.567" - 2.125"	.689"

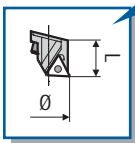

- Must purchase at least 1 component from each chart above marked with a (\*) for the 10% savings.
- Additional components above qualify for the 10% savings only during original order.
- Side mount insert holders not included in promo.

- Must mention promo code "PROMO-KAIRATH".
- Expires 03/31/10.
- No order limit.

# BIG KAISER®

**PRECISION TOOLING INC.**

2600 Huntington Blvd., Hoffman Estates, IL 60192

Tel: 847.228.7660 • Fax: 847.228.0881

Web: www.bigkaiser.com • E-mail: bigkaiser@bigkaiser.com